

# Kit Contents

## REVISIONS

REV	DESCRIPTION	DATE	APPROVED
C	NEW BRACKETS AND HDWR PER ECO 12-15642	10/03/12	RGH
D	UPDATED 8-32 SCREW LENGTH PER ECO 12-15948	12/19/12	JAK
E	ADDED WEIGHT PER ECO 13-17175	9/24/13	DS

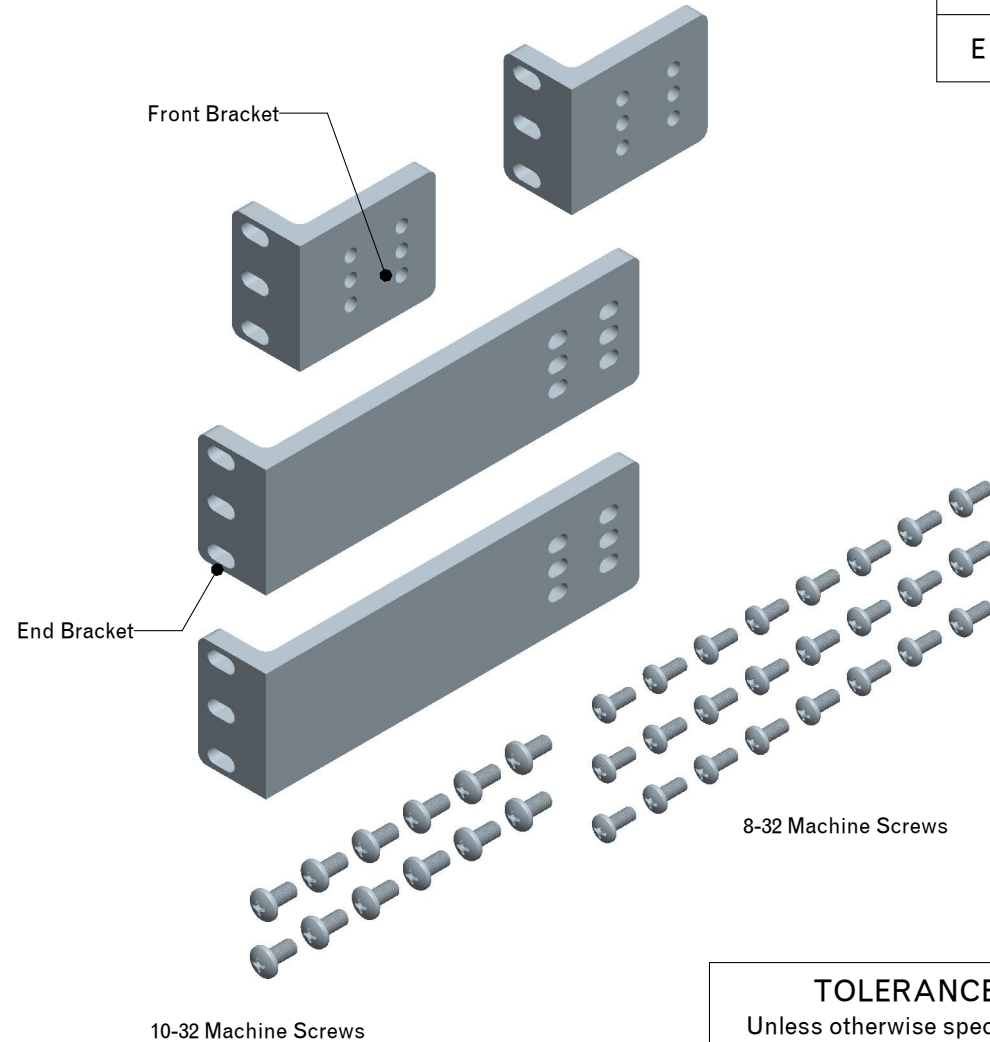

### KIT CONTAINS:

1. QTY: 2 - FRONT BRACKET
2. END BRACKET, QTY: 2
3. QTY: 24 - 18-8 SS PAN HEAD, PHILIPS MACHINE SCREW 8-32 THREAD, 1/2" LENGTH
4. QTY: 12 - 18-8 SS PAN HEAD, PHILIPS MACHINE SCREW 10-32 THREAD 1/2" LENGTH

A

B

C

A

B

C

- NOTES:  
 1. REFERENCE SYNQOR SPECIFICATION: 554-0000002  
 2. WEIGHT: .86 lbs (.386 kg)

**TOLERANCES:**  
 Unless otherwise specified:  
 All dimensions in inches  
 .X +/- .025  
 .XX +/- .010  
 .XXX +/- .005  
 Angles +/- 1°

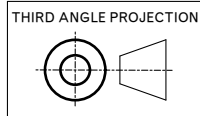

THIS DRAWING IS THE PROPERTY OF SYNQOR INC.  
 It is not to be reproduced or copied, in whole or in part, or used for furnishing information to others, or for any purpose detrimental to the interests of SynQor. The information shown herein may be protected by patents owned or controlled by SynQor.



155 Swanson Road  
 Boxborough, MA 01719

## UPS 1U HARD MOUNT BRACKET SET

SOURCE: PRO/E model\_name:2

SIZE	DATE	DWG. NO.	REV
A	12/19/12	SYN-9031	E
SCALE: 0.500		DRAWN: RGH	CHECK: SHEET 1 of 5

1

2

3

4

1

2

3

4

# Bracket - Rack Mounting Diagram

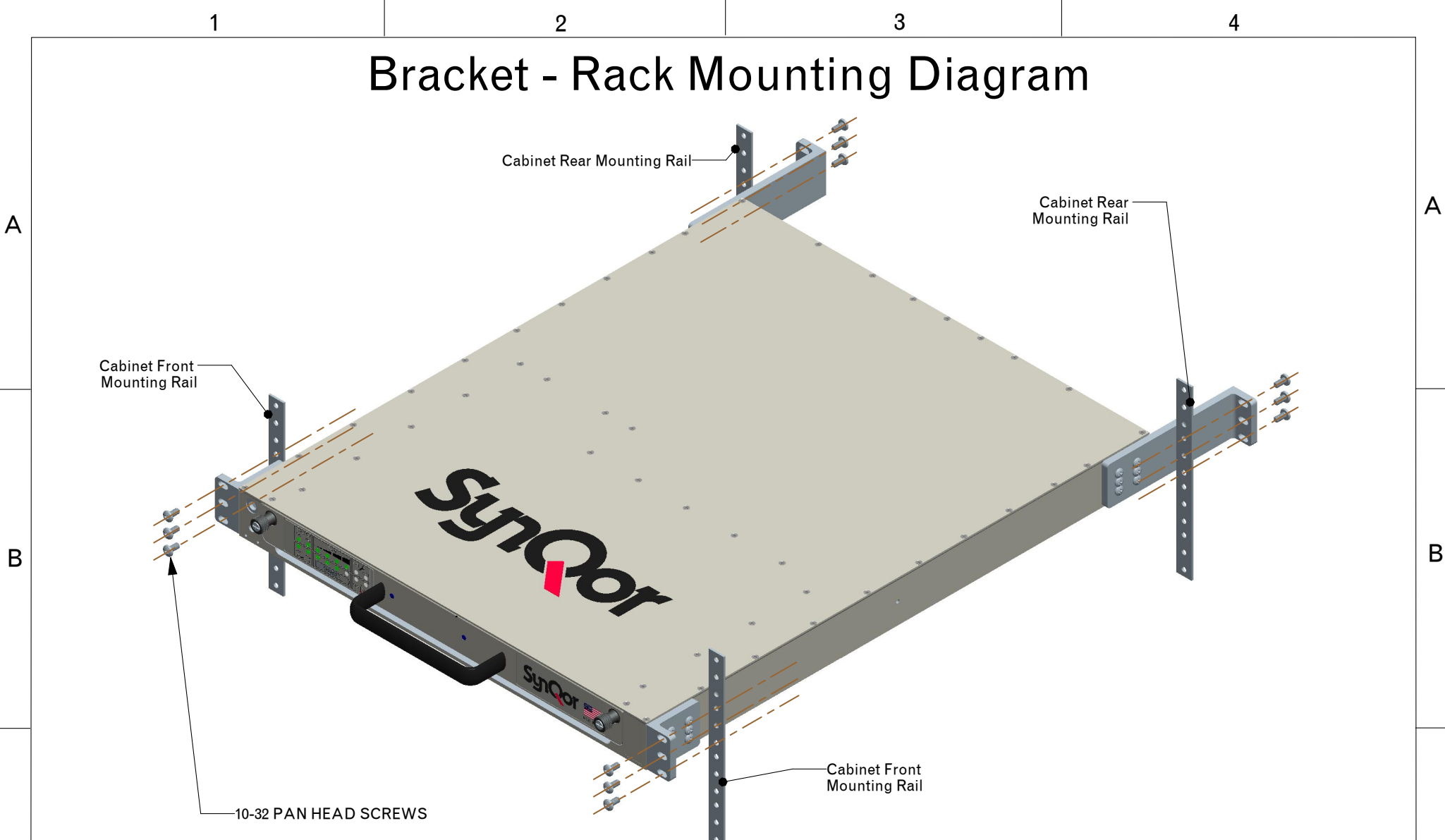

**TOLERANCES:**

Unless otherwise specified:  
All dimensions in inches

- .X +/- .025
- .XX +/- .010
- .XXX +/- .005
- Angles +/- 1°

THIRD ANGLE PROJECTION

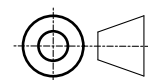

THIS DRAWING IS THE PROPERTY OF SYNQOR INC.  
It is not to be reproduced or copied, in whole  
or in part, or used for furnishing information  
to others, or for any purpose detrimental to the  
interests of SynQor. The information shown herein  
may be protected by patents owned or controlled by SynQor.



155 Swanson Road  
Boxborough, MA 01719

## UPS 1U HARD MOUNT BRACKET SET

SOURCE: PRO/E model\_name:2

SIZE	DATE	DWG. NO.	REV
A	12/19/12	SYN-9031	E

SCALE: 0.250    DRAWN: RGH    CHECK:    SHEET 2 of 5

# Bracket - Chassis Mount Diagram

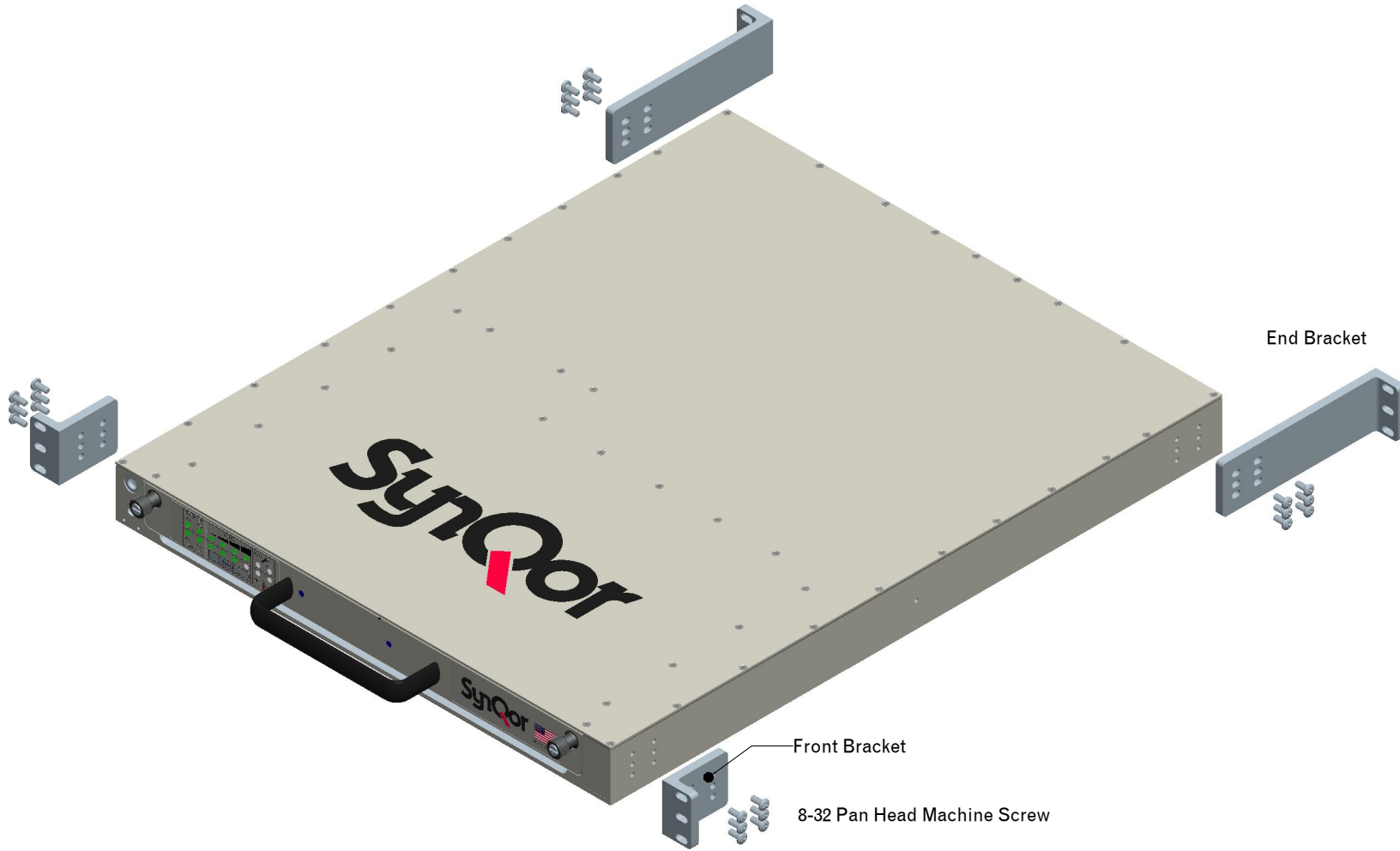

### TOLERANCES:

Unless otherwise specified:  
All dimensions in inches

.X +/- .025

.XX +/- .010

.XXX +/- .005

Angles +/- 1°

THIRD ANGLE PROJECTION

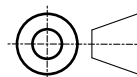

THIS DRAWING IS THE PROPERTY OF SYNQOR INC.  
It is not to be reproduced or copied, in whole  
or in part, or used for furnishing information  
to others, or for any purpose detrimental to the  
interests of SynQor. The information shown herein  
may be protected by patents owned or controlled by SynQor.

155 Swanson Road  
Boxborough, MA 01719

## UPS 1U HARD MOUNT BRACKET SET

SOURCE: PRO/E model\_name:2

SIZE	DATE	DWG. NO.	REV
A	12/19/12	SYN-9031	E

SCALE: 0.250    DRAWN: RGH    CHECK:    SHEET 3 of 5

1

2

3

4

A

A

B

B

C

C

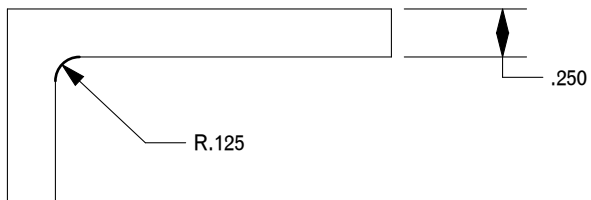

NOTES:  
 1. MATERIAL: 6061-T6 ALUMINUM  
 2. FINISH: CLEAR ANODIZED

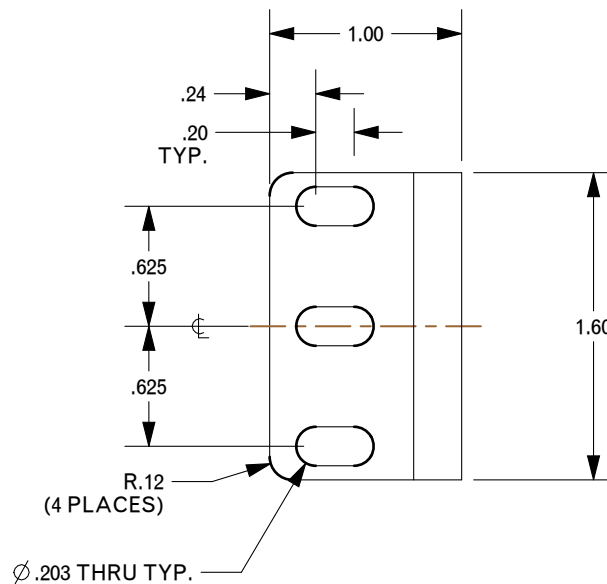
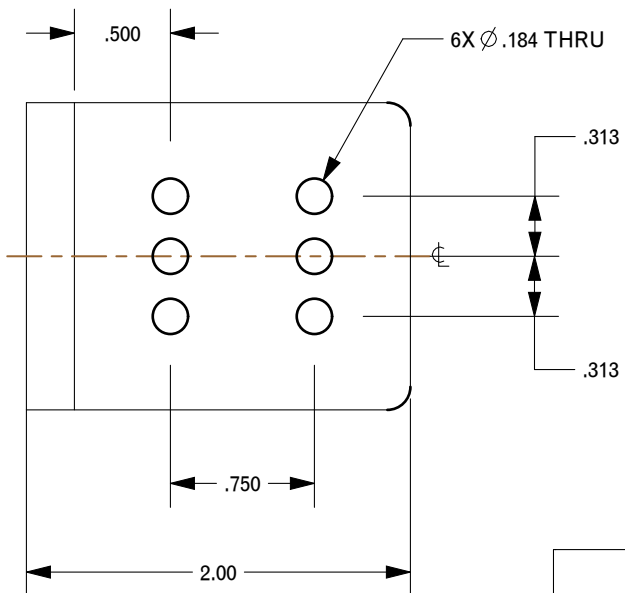

**TOLERANCES:**

Unless otherwise specified:  
 All dimensions in inches  
 .X +/- .025  
 .XX +/- .010  
 .XXX +/- .005  
 Angles +/- 1°

THIRD ANGLE PROJECTION

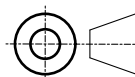

THIS DRAWING IS THE PROPERTY OF SYNQOR INC.  
 It is not to be reproduced or copied, in whole  
 or in part, or used for furnishing information  
 to others, or for any purpose detrimental to the  
 interests of SynQor. The information shown herein  
 may be protected by patents owned or controlled by SynQor.



155 Swanson Road  
 Boxborough, MA 01719

**UPS 1U HARD MOUNT BRACKET SET**

SOURCE: PRO/E UPS\_1U\_HARD\_MOUNT\_FRONT

SIZE	DATE	DWG. NO.	REV
A	12/19/12	SYN-9031	E

SCALE: 1.000    DRAWN: RGH    CHECK:    SHEET 4 of 5

1

2

3

4

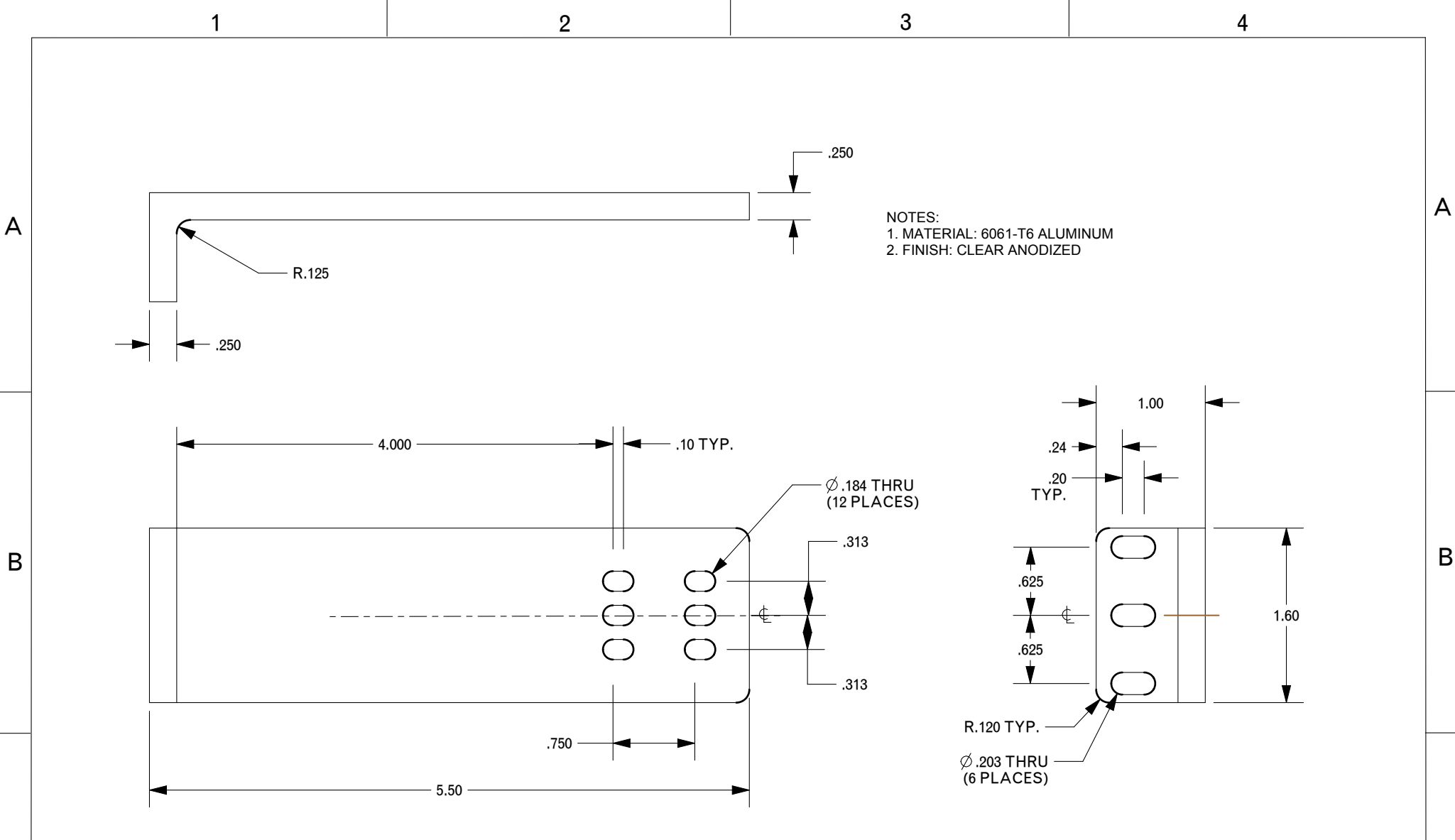

**TOLERANCES:**

Unless otherwise specified:  
All dimensions in inches

- .X +/- .025
- .XX +/- .010
- .XXX +/- .005
- Angles +/- 1°

THIRD ANGLE PROJECTION

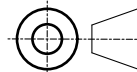

THIS DRAWING IS THE PROPERTY OF SYNQOR INC.  
It is not to be reproduced or copied, in whole  
or in part, or used for furnishing information  
to others, or for any purpose detrimental to the  
interests of SynQor. The information shown herein  
may be protected by patents owned or controlled by SynQor.



155 Swanson Road  
Boxborough, MA 01719

**UPS 1U HARD MOUNT BRACKET SET**

SOURCE: PRO/E UPS\_1U\_REAR

SIZE	DATE	DWG. NO.	REV
A	12/19/12	SYN-9031	E

SCALE: 0.800    DRAWN: RGH    CHECK:    SHEET 5 of 5